

Notes:-

1. The legend is from the Transport Heavy alphabet at the 'x'-heights shown.
2. Details of the recovery vehicle symbol are given on drawing no. S 63.
3. The outlines of the tiles do not form part of the sign.
4. The colours are as follows:-  
Border, legend \_\_\_\_\_ Black  
and symbol \_\_\_\_\_  
Background \_\_\_\_\_ Yellow
5. The illumination of the sign must accord with the requirements of the current Traffic Signs Regulations and General Directions.
6. The 'x'-heights shown are given in millimetres, all other dimensions are given in stroke widths (i.e.  $1s/w = 1/4 \times \text{'x'-height}$ ).
7. The order of languages may be reversed if required.

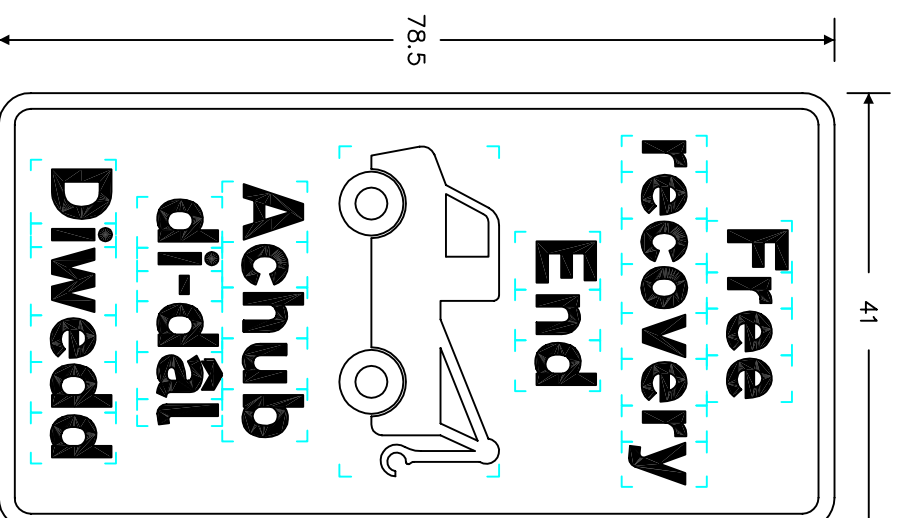
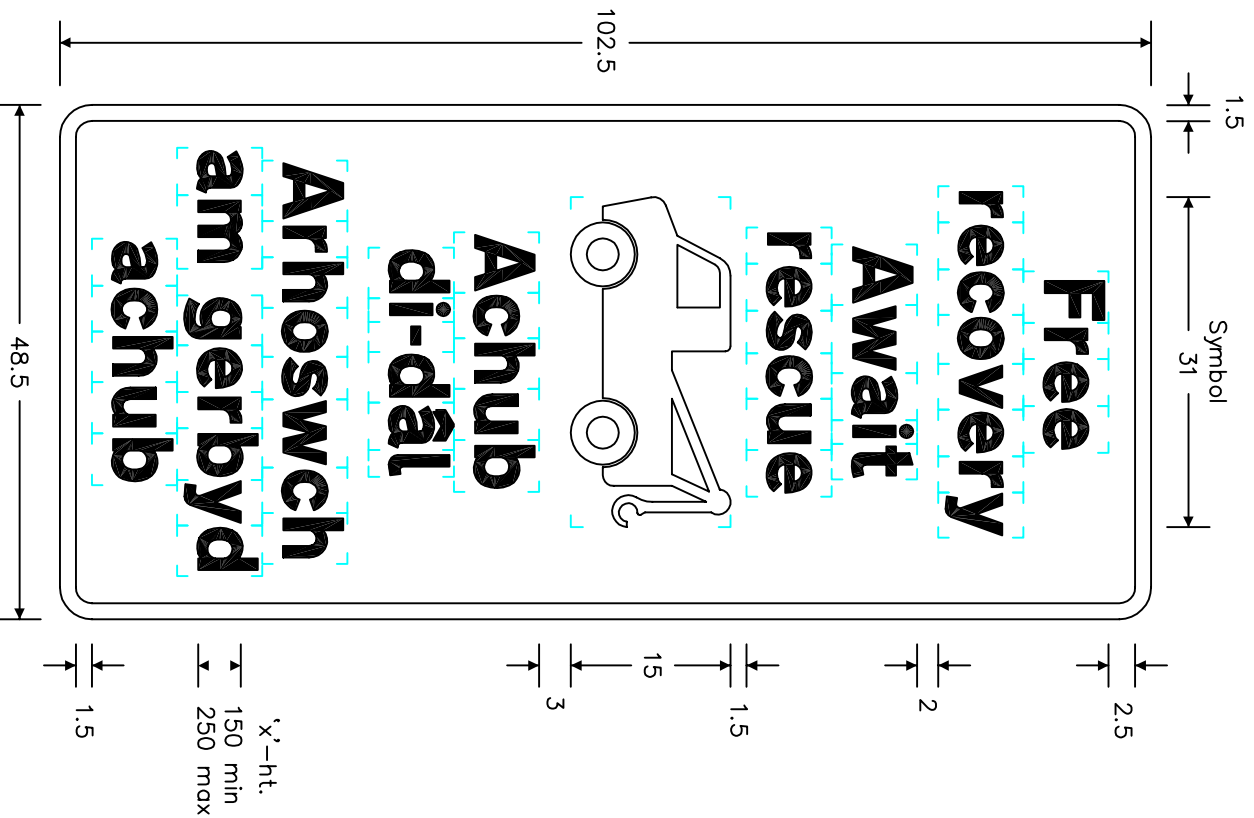

VARIANT

REVISIONS	
1.	Variant added & notes amended 22.12.06

Before using this drawing confirm with RNMS Division that it has not been superseded.

Dn. A.T.I. Appd. \_\_\_\_\_

Chkd. \_\_\_\_\_ Appl. dote 17.2.97

Issue: 22.12.06

Scale: Photo-reduced

Title Temporary Informatory sign

FREE RECOVERY

WELSH ASSEMBLY GOVERNMENT

Drwg. no. WAG/P 7291